

Modbus Unsolicited Serial Device Driver Help

© 2009 Kepware Technologies

Table of Contents

1	Getting Started	2
	Help Contents.....	2
	Overview.....	2
2	Device Setup	3
	Device Setup.....	3
	Cable Diagram.....	3
	Modem Setup.....	4
	Memory.....	4
	Timeout.....	7
3	Data Types Description	7
	Data Types Description.....	7
4	Address Descriptions	8
	Address Descriptions.....	8
	Modbus Addressing.....	8
	Daniels/Enron Addressing.....	9
5	Error Descriptions	11
	Error Descriptions.....	11
	Modbus Exception Codes.....	11
	Address Validation.....	12
	Address Validation.....	12
	Missing address.....	12
	Device address '<address>' contains a syntax error.....	12
	Address '<address>' is out of range for the specified device or register.....	13
	Data Type '<type>' is not valid for device address '<address>'.....	13
	Device address '<address>' is Read Only.....	13
	Array size is out of range for address '<address>'.....	13
	Array support is not available for the specified address: '<address>'.....	13
	Serial Communications.....	14
	Serial Communications.....	14
	COMn does not exist.....	14
	Error opening COMn.....	14
	COMn is in use by another application.....	14
	Unable to set comm parameters on COMn.....	14
	Communications error on COMn [<error mask>].....	15
	Device Status Messages.....	15
	Device Status Messages.....	15
	Device '<device name>' is not responding.....	15
	Unable to write to '<address>' on device '<device name>'.....	15
	Device Specific Messages.....	16
	Device Specific Messages.....	16
	Address size for device '<device name>' changed from '<old address size>' to '<new address size>'.....	16

Modbus Unsolicited Serial Device Driver Help

Help version 1.021

CONTENTS

Overview

What is the Modbus Unsolicited Serial Device Driver?

Device Setup

How do I configure a device for use with this driver?

Data Types Description

What data types does this driver support?

Address Descriptions

How do I address a data location in an unsolicited device?

Error Descriptions

What error messages does the Modbus Unsolicited device driver produce?

Overview

The Modbus Unsolicited Serial Device Driver was designed specifically for use with 32 bit OPC server products running on Intel microprocessor based computers. For operating system (OS) requirements, please refer to the OPC server help documentation.

The Modbus Unsolicited driver simulates up to 255 Modbus slave devices on a serial communications network. Other devices or PC's can communicate with each simulated Modbus slave device using the Modbus protocol.

The simulated Modbus slave devices will respond to the following function codes:

- Read Coil Status-code 01H
- Read Input Status-code 02H
- Read Holding Registers-code 03H
- Read Internal Registers-code 04H
- Force Single Coil-code 05H
- Preset Single Register-code 06H
- Diagnostic Loopback-code 08H
- Force Multiple Coils-code 0FH
- Preset Multiple Registers-code 10H

Note: For all other function codes, the driver will return an exception code 01H, function not implemented, to the requesting device.

The following memory locations are accessible in the simulated device:

- Output coils-00001 to 065536
- Input coils-10001 to 165536
- Internal registers-30001 to 365536>
- Holding registers-40001 to 465536

Note: These settings are configurable. For more information, refer to [Memory](#).

Broadcast Commands

The Modbus Unsolicited Serial driver has the ability to receive broadcast write messages. Broadcast messages are defined by using a station ID of 0. When the driver receives a write message (Function 05H, 06H, 0FH, or 10H), with a station ID of 0 the value to be written is placed in all devices defined under the channel on which the command was received. Essentially the broadcast command can be used to send a single piece of data to every device you have configured in the driver at the same time.

Note: For this driver, the terms Slave and Unsolicited are used interchangeably.

Device Setup

Supported Devices

Modbus compatible devices.

Communication Protocol

Modbus RTU Protocol.

Supported Communication Parameters*

Baud Rate: 1200, 2400, 9600, 19200

Parity: Odd, Even, None

Data Bits: 8

Stop Bits: 1, 2

*Not all devices support the listed configurations.

Device ID (PLC Network Address)

Modbus Serial devices are assigned Device IDs in the range 1 to 255.

Flow Control

When using an RS232/RS485 converter, the type of flow control that is required will depend upon the needs of the converter. Some converters do not require any flow control and others will require RTS flow. Consult the converter's documentation in order to determine its flow requirements. We recommend using an RS485 converted that provides automatic flow control.

Note: When using the manufacturer's supplied communications cable, it is sometimes necessary to choose a flow control setting of **RTS** or **RTS Always** under the Channel Properties.

See Also: [Cable Diagram](#), [Memory](#) and [Timeout](#).

Note: For this driver, the terms Slave and Unsolicited are used interchangeably.

Cable Diagram

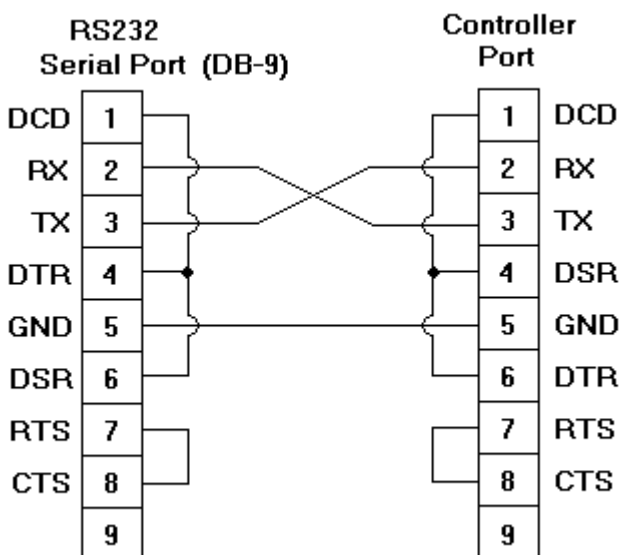

Modem Setup

This driver supports modem functionality. For more information, please refer to the topic "Modem Support" in the OPC Server Help documentation.

Memory

Allowed Address Range

The address range of coils and registers can be configured, and any value between 9999 and 65536 can be specified. The tags can then be addressed up to and including the specified value. Note the following:

1. The address range cannot be changed when the tags are being processed.
2. When the address range is changed, it is possible that a remote request (from a Modbus master) will get rejected because the requested memory address is outside the new address range.
3. When the address range is changed, and the new upper limit is greater than the old one, all old data is completely preserved and the remaining memory is initialized to '0'. On the other hand, if the new upper limit is smaller than the old one, then only the data equal to the new memory size is preserved and the remaining data is lost. There might be an exception to this when dealing with Boolean memory type. The following example explains how: Assume that the initial memory size is 21 (a small number for simplicity sake). This translates into 3 bytes (byte aligned) of memory for Boolean types. Now, say the memory size is changed to 12 (which is 2 bytes). The smaller of the two memory sizes is 2 bytes and that is the amount of data that is preserved. Note, however, that the user probably thinks only 12 bits have been preserved though in reality 16 bits (2 bytes) have been preserved. Normally this would not be noticed, as with a memory size of 12, memory can be accessed up to index 12 only. Now, if the memory size is increased, say, to 22 (which is 3 bytes) the amount of data that will be preserved from the old memory is 2 bytes (smaller of the two). You can see that even though the user manipulated only 12 bits earlier (with a memory size of 12), he will have old data for bits 13- 16 which may have been initialized to some values the first time around (when the memory size was 21).

The images below are a diagrammatic explanation of the details discussed above when applied to a coil memory type.

STEP I:

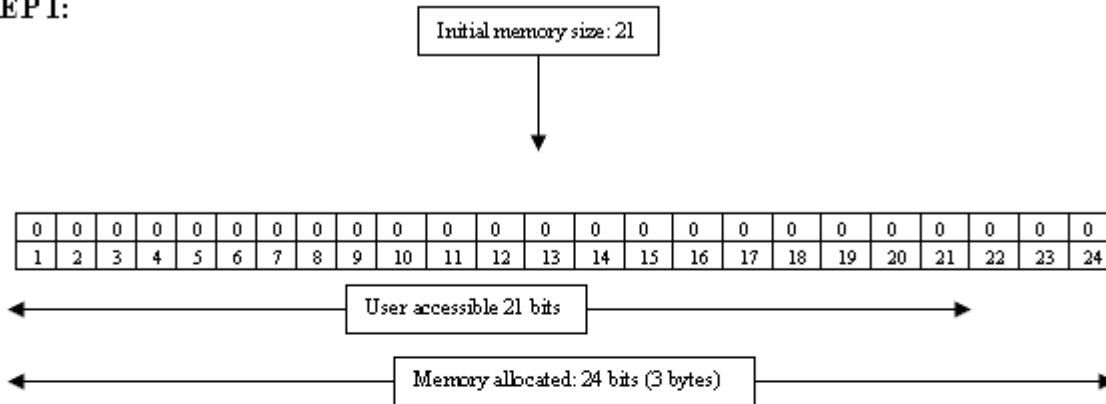

STEP II:

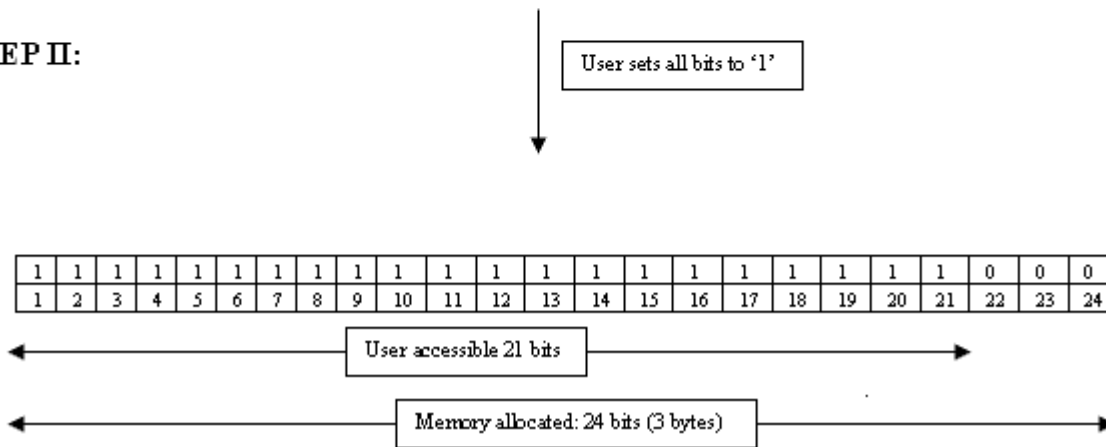

STEP III:

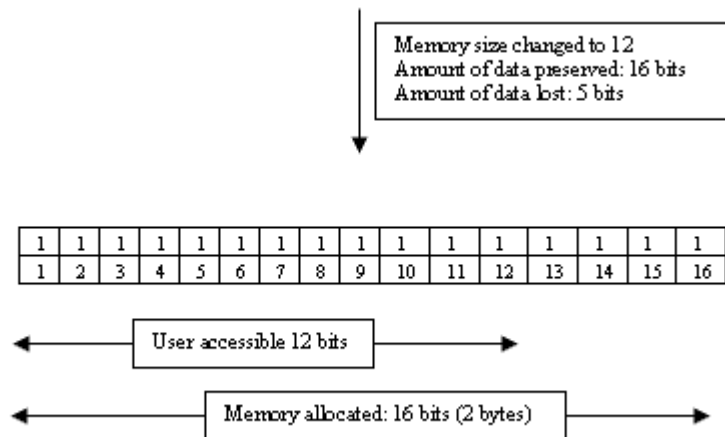

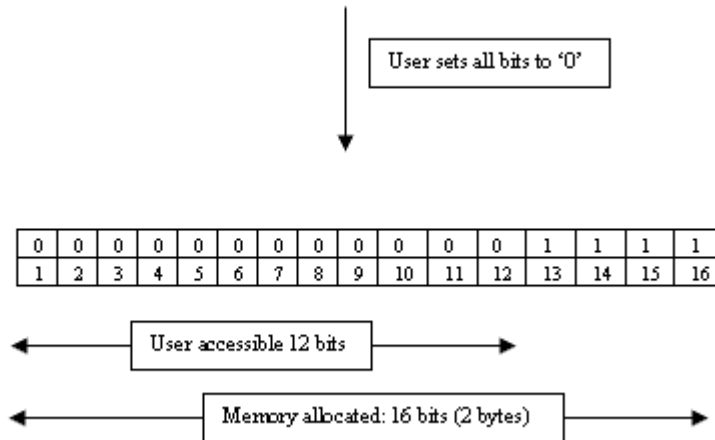
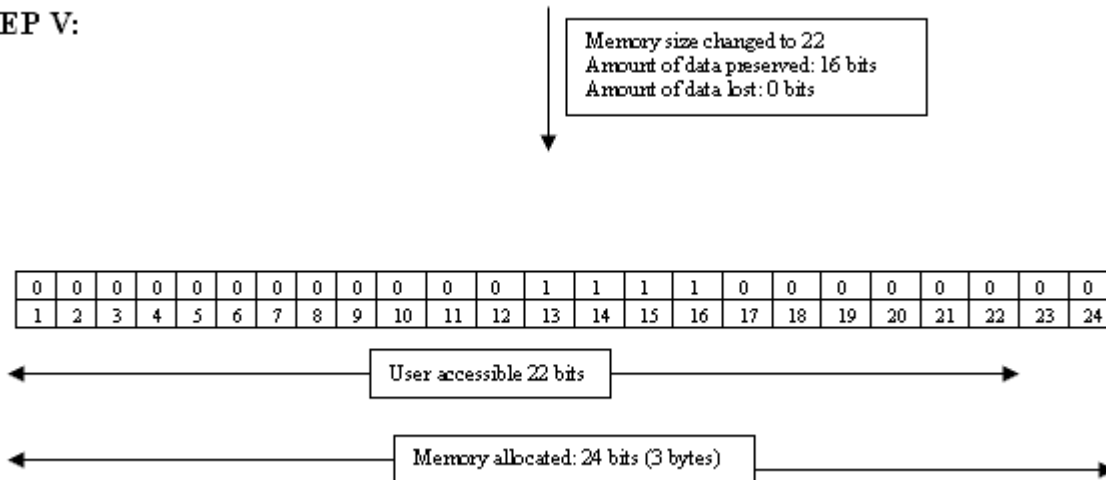
STEP IV:**STEP V:**

Step V above shows old data for bits 13-16 that were initialized in step II. The user expects all the bits in step V to be '0' but bits 13-16 have been carried over from step II and are still set to '1'.

Zero vs. One Based Addressing

If the address numbering convention for your device starts at one as opposed to zero you can specify this when defining the parameters for your device. By default, user-entered addresses will have one subtracted from them when frames are constructed to communicate with a Modbus device. If the device doesn't follow this convention, uncheck the **Use zero based addressing** check box in Device Properties. Refer to the online help for the appropriate application to obtain information on setting device properties. The default behavior follows the convention of the Modicon PLCs.

Note: 'Use zero based addressing' must be unchecked when using the Daniels/Enron Device.

First word low in 32 bit data types

Two consecutive register addresses in a Modbus device are used for 32-bit data types. Users can specify whether the driver should assume the first word is the low or the high word of the 32-bit value. If **First word low in 32 bit data types** is checked (the default), first word low will be assumed, which follows the convention of the Modicon Modsoft programming software.

Note: 'First word low in 32 bit data types' must be unchecked when using the Daniels/Enron Device.

First DWord low in 64 bit data types

Four consecutive register addresses (in two groups of two each) are used for 64-bit data types. Users can specify whether the driver should assume the first pair (i.e., first DWord) is the low or the high DWord of the 64-bit value. If **First DWord low in 64 bit data types** is checked, the first DWord low will be assumed; if unchecked, the second DWord low will be assumed.

Note: 'First DWord low in 64 bit data types' must be unchecked when using the Daniels/Enron Device.

OPC Quality Bad Until Write

This option controls the initial OPC quality of tags attached to this driver. When unchecked, all tags will have an initial value of 0 and Good OPC quality. This is the default condition. When checked, All tags will have an initial value of 0 and Bad OPC quality. The quality of a tag will remain Bad until all coils or registers referenced by the tag have been written to by a Modbus master or a client application. For example, a tag with address 400001 and data type DWORD references two holding registers: 400001 and 400002. This tag would not show Good quality until both holding registers had been written to.

Timeout

Communications Timeout

Allows the user to set the amount of time the driver will wait for an incoming request before setting all unsolicited device tags on the Channel to a **Bad Quality**. After a communications timeout has occurred, the only way to reset the timeout and allow all tags be processed normally is to reestablish communications with the device or disable the timeout by setting **Communications Timeout to 0** (zero) in the **Timeout** tab under Channel Properties.

Disabled: 0

Enabled: 1-->64,800 seconds(18 hours)

Request Timeout

Allows the user to set the amount of time the driver will wait for a complete request frame to be received. The elapsed time is calculated starting from the instant the first byte of a new request is received. If a complete request frame is not received during this time, the driver will flush its received data buffers and assume the next received byte is the start of a new request. This setting should be chosen carefully.

Values for the Request Timeout setting may range from 0 to 30,000 ms, with a default of 0. When 0 is entered, the driver will compute a reasonable timeout for you, using the following formula:

$$T_{\text{default}} = 1000 * (\text{Bits per Byte}) * 512 * 3 / \text{Baud}$$

This is 3 times the amount of time required to transmit a frame of 512 bytes. The number of bits per byte includes the start bit and the number of data and stop bits specified in the **Communications** tab under **Channel Properties**. For example, a baud rate of 9600 and 8 data bits, and 1 stop bit, will result in a default timeout of 1600 ms. If the hardware sends relatively short request frames and would retry a failed request in less than the default calculation (1600 ms in this example), try configuring a shorter **Request Timeout**.

The Request Timeout should never be shorter than the amount of time it takes to receive the longest request frame sent by any device on the channel. This can be computed using the following formula:

$$T_{\text{min}} = 1000 * (\text{Bits per Byte}) * (\text{max frame length}) / \text{Baud}$$

Note: For this driver, the terms Slave and Unsolicited are used interchangeably.

Data Types Description

Data Type	Description
Boolean	Single bit
Word	Unsigned 16 bit value bit 0 is the low bit bit 15 is the high bit
Short	Signed 16 bit value bit 0 is the low bit

	bit 14 is the high bit bit 15 is the sign bit
DWord	Unsigned 32 bit value
	bit 0 is the low bit bit 31 is the high bit
Long	Signed 32 bit value
	bit 0 is the low bit bit 30 is the high bit bit 31 is the sign bit
BCD	Two byte packed BCD
	Value range is 0-9999. Behavior is undefined for values beyond this range.
LBCD	Four byte packed BCD
	Value range is 0-99999999. Behavior is undefined for values beyond this range.
String	Null terminated ASCII string
	Supported within the Holding Register Range, includes HiLo LoHi byte order selection.
Double*	64 bit floating point value
	The driver interprets four consecutive registers as a double precision value by making the last two registers the high DWord and the first two registers the low DWord.
Double Example	If register 40001 is specified as a double, bit 0 of register 40001 would be bit 0 of the 64 bit data type and bit 15 of register 40004 would be bit 63 of the 64 bit data type.
Float*	32 bit floating point value
	The driver interprets two consecutive registers as a single precision value by making the last register the high word and the first register the low word.
Float Example	If register 40001 is specified as a float, bit 0 of register 40001 would be bit 0 of the 32 bit data type and bit 15 of register 40002 would be bit 31 of the 32 bit data type.

*The descriptions assume the default-first DWord low data handling of 64 bit data types, and first word low data handling of 32 bit data types.

Address Descriptions

Address specifications vary depending on the model in use. Select a link from the following list to obtain specific address information for the model of interest.

[Modbus Addressing](#)
[Daniels/Enron Addressing](#)

Modbus Addressing

The following address descriptions apply to the client application's access to each simulated Modbus slave device. The client application controls the memory of the simulated Modbus slave device; therefore all areas have Read/Write access.

Default data types for dynamically defined tags are shown in **bold** where appropriate.

Address	Range*	Data Type	Access
---------	--------	-----------	--------

Output Coils	000001-065536	Boolean	Read/Write
Input Coils	100001-165536	Boolean	Read/Write
Internal Registers	300001-365536 300001-365535 3xxxxx.0-3xxxxx.15	Word , Short, BCD Float, DWord, Long, LBCD Boolean, Double	Read/Write
Holding Registers	400001-465536 400001-465535 4xxxxx.0-4xxxxx.15	Word , Short, BCD Float, DWord, Long, LBCD Boolean, Double	Read/Write
Holding Registers As String with HiLo Byte Order	400001.2H-465536.240H .Bit is string length, range 2 to 240 bytes.	String	Read/Write
Holding Registers As String with LoHi Byte Order	400001.2L-465536.240L .Bit is string length, range 2 to 240 bytes.	String	Read/Write

*The maximum range is determined by the value set in the Memory device property. For more information, refer to [Memory](#).

Array Support

Arrays are supported for internal and holding register locations for all data types except for Boolean. Arrays are also supported for input and output coils (Boolean data types). There are two methods of addressing an array. Examples are given using holding register locations.

4xxxx [rows] [cols]

4xxxx [cols] this method assumes rows is equal to one

For Word, Short and BCD arrays, the base address + (rows *cols) cannot exceed 65536.

For Float, DWord, Long and Long BCD arrays, the base address + (rows *cols *2) cannot exceed 65535.

String Support

The Modbus model supports reading and writing holding register memory as an ASCII string. When using holding registers for string data, each register will contain two bytes of ASCII data. The order of the ASCII data within a given register can be selected when the string is defined. The length of the string can be from 2 to 240 bytes and is entered in place of a bit number. The length must be entered as an even number. The byte order is specified by appending either a "H" or "L" to the address.

String Examples

1. To address a string starting at 400200 with a length of 100 bytes and HiLo byte order, enter:
400200.100H

2. To address a string starting at 400500 with a length of 78 bytes and LoHi byte order, enter:
400500.78L

Note: For this driver, the terms Slave and Unsolicited are used interchangeably.

Daniels/Enron Addressing

The following address descriptions apply to the client application's access to each simulated Daniels/Enron slave device. The client application controls the memory of the simulated slave device; therefore all areas have Read/Write access.

The default data types for dynamically defined tags are shown in **bold** where appropriate. The following table assumes that the slave device has been configured for the maximum allowed address range of 0 to 65535. For more information, refer to [Memory](#).

Address	Range*	Data Type	Access
Output Coils	000000-065535	Boolean	Read/Write
Input Coils	100000-165535	Boolean	Read/Write
Internal Registers	300000-365535 300000-365534	Word , Short, BCD Float, DWord, Long, LBCD	Read/Write

	300000-365532 300000.0-365535.15	Double Boolean	
Holding Registers	400000-405000 406000-407000 408000-465535	Word , Short, BCD	Read/Write
	400000-404999 406000-406999 408000-465534	DWord, LBCD	
	400000-404999 405001-405999 406000-406999 408000-465534	Long	
	400000-404999 406000-406999 407001-407999 408000-465534	Float	
	400000-404997 406000-406997 408000-465532	Double	
Holding Registers as Booleans	400000.xx-405000.xx 405001.yy-405999.yy 406000.xx-465535.xx xx is the bit number from 0-15 yy is the bit number from 0-31	Boolean	Read/Write
Holding Registers As String with HiLo Byte Order	400000.xxxH-405000.xxxH 406000.xxxH-407000.xxxH 408000.xxxH-465535.xxxH xxx is string length, range 2 to 240 bytes.	String	Read/Write
Holding Registers As String with LoHi Byte Order	400000.xxxL-405000.xxxL 406000.xxxL-407000.xxxL 408000.xxxL-465535.xxxL xxx is string length, range 2 to 240 bytes.	String	Read/Write

*The maximum range is determined by the value set in the Memory device property. For more information, refer to [Memory](#).

Array Support

Arrays are supported for internal and holding register locations for all data types except for Boolean. Arrays are also supported for input and output coils (Boolean data types). There are two methods of addressing an array. Examples are given using holding register locations.

4xxxx [rows] [cols]

4xxxx [cols] this method assumes rows is equal to one

For Word, Short and BCD arrays, the base address + (rows *cols) cannot exceed 65535.

For Float, DWord, Long and Long BCD arrays, the base address + (rows *cols *2) cannot exceed 65534.

String Support

The Modbus model supports reading and writing holding register memory as an ASCII string. When using holding registers for string data, each register will contain two bytes of ASCII data. The order of the ASCII data within a given register can be selected when the string is defined. The length of the string can be from 2 to 240 bytes and is entered in place of a bit number. The length must be entered as an even number. The byte order is specified by appending either a "H" or "L" to the address.

String Examples

1. To address a string starting at 400200 with a length of 100 bytes and HiLo byte order, enter:
400200.100H
2. To address a string starting at 400500 with a length of 78 bytes and LoHi byte order, enter:
400500.78L

Note: For this driver, the terms Slave and Unsolicited are used interchangeably.

Error Descriptions

The following error/warning messages may be generated. Click on the link for a description of the message.

Address Validation

[Missing address](#)

[Device address '<address>' contains a syntax error](#)

[Address '<address>' is out of range for the specified device or register](#)

[Data Type '<type>' is not valid for device address '<address>'](#)

[Device address '<address>' is Read Only](#)

[Array size is out of range for address '<address>'](#)

[Array support is not available for the specified address: '<address>'](#)

Serial Communications

[COMn does not exist](#)

[Error opening COMn](#)

[COMn is in use by another application](#)

[Unable to set comm parameters on COMn](#)

[Communications error on COMn \[<error mask>\]](#)

Device Status Messages

[Device '<device name>' is not responding](#)

[Unable to write to '<address>' on device '<device name>'](#)

Device Specific Messages

[Address size for device '<device name>' changed from '<old address size>' to '<new address size>'](#)

See Also:

[Modbus Exception Codes](#)

Modbus Exception Codes

The following data is from Modbus Application Protocol Specifications documentation.

Code Dec/Hex	Name	Meaning
01/0x01	ILLEGAL FUNCTION	The function code received in the query is not an allowable action for the server (or slave). This may be because the function code is only applicable to newer devices, and was not implemented in the unit selected. It could also indicate that the server (or slave) is in the wrong state to process a request of this type, for example because it is unconfigured and is being asked to return register values.
02/0x02	ILLEGAL DATA ADDRESS	The data address received in the query is not an allowable address for the server (or slave). More specifically, the combination of reference number and transfer length is invalid. For a controller with 100 registers, a request with offset 96 and length 4 would succeed, a request with offset 96 and length 5 will generate exception 02.
03/0x03	ILLEGAL DATA VALUE	A value contained in the query data field is not an allowable value for server (or slave). This indicates a fault in the structure of the remainder of a complex request, such as that the implied length is incorrect. It specifically does NOT

		mean that a data item submitted for storage in a register has a value outside the expectation of the application program, since the MODBUS protocol is unaware of the significance of any particular value of any particular register.
04/0x04	SLAVE DEVICE FAILURE	An unrecoverable error occurred while the server (or slave) was attempting to perform the requested action.
05/0x05	ACKNOWLEDG E	The slave has accepted the request and is processing it, but a long duration of time will be required to do so. This response is returned to prevent a timeout error from occurring in the master. The master can next issue a Poll Program Complete message to determine if processing is completed.
06/0x06	SLAVE DEVICE BUSY	The slave is engaged in processing a long-duration program command. The master should retransmit the message later when the slave is free.
07/0x07	NEGATIVE ACKNOWLEDG E	The slave cannot perform the program function received in the query. This code is returned for an unsuccessful programming request using function code 13 or 14 decimal. The master should request diagnostic or error information from the slave.
08/0x08	MEMORY PARITY ERROR	The slave attempted to read extended memory, but detected a parity error in the memory. The master can retry the request, but service may be required on the slave device.
10/0x0A	GATEWAY PATH UNAVAILABLE	Specialized use in conjunction with gateways, indicates that the gateway was unable to allocate an internal communication path from the input port to the output port for processing the request. This usually means that the gateway is misconfigured or overloaded.
11/0x0B	GATEWAY TARGET DEVICE FAILED TO RESPOND	Specialized use in conjunction with gateways, indicates that no response was obtained from the target device. Usually means that the device is not present on the network.

Note: For this driver, the terms Slave and Unsolicited are used interchangeably.

Address Validation

The following error/warning messages may be generated. Click on the link for a description of the message.

Address Validation

[Missing address](#)

[Device address '<address>' contains a syntax error](#)

[Address '<address>' is out of range for the specified device or register](#)

[Data Type '<type>' is not valid for device address '<address>'](#)

[Device address '<address>' is Read Only](#)

[Array size is out of range for address '<address>'](#)

[Array support is not available for the specified address: '<address>'](#)

Missing address

Error Type:

Warning

Possible Cause:

A tag address that has been specified dynamically has no length.

Solution:

Re-enter the address in the client application.

Device address '<address>' contains a syntax error

Error Type:

Warning

Possible Cause:

A tag address that has been specified dynamically contains one or more invalid characters.

Solution:

Re-enter the address in the client application.

Address '<address>' is out of range for the specified device or register

Error Type:

Warning

Possible Cause:

A tag address that has been specified dynamically references a location that is beyond the range of supported locations for the device.

Solution:

Verify the address is correct; if it is not, re-enter it in the client application.

Data Type '<type>' is not valid for device address '<address>'

Error Type:

Warning

Possible Cause:

A tag address that has been specified dynamically has been assigned an invalid data type.

Solution:

Modify the requested data type in the client application.

Device address '<address>' is Read Only

Error Type:

Warning

Possible Cause:

A tag address that has been specified dynamically has a requested access mode that is not compatible with what the device supports for that address.

Solution:

Change the access mode in the client application.

Array size is out of range for address '<address>'

Error Type:

Warning

Possible Cause:

A tag address that has been specified dynamically is requesting an array size that is too large for the address type.

Solution:

Re-enter the address in the client application to specify a smaller value for the array or a different starting point.

Array support is not available for the specified address: '<address>'

Error Type:

Warning

Possible Cause:

A tag address that has been specified dynamically contains an array reference for an address type that doesn't support arrays.

Solution:

Re-enter the address in the client application to remove the array reference or correct the address type.

Serial Communications

The following error/warning messages may be generated. Click on the link for a description of the message.

Serial Communications

[COMn does not exist](#)

[Error opening COMn](#)

[COMn is in use by another application](#)

[Unable to set comm parameters on COMn](#)

[Communications error on COMn \[<error mask>\]](#)

COMn does not exist

Error Type:

Fatal

Possible Cause:

The specified COM port is not present on the target computer.

Solution:

Verify that the proper COM port has been selected.

Error opening COMn

Error Type:

Fatal

Possible Cause:

The specified COM port could not be opened due an internal hardware or software problem on the target computer.

Solution:

Verify that the COM port is functional and may be accessed by other Windows applications.

COMn is in use by another application

Error Type:

Fatal

Possible Cause:

The serial port assigned to a device is being used by another application.

Solution:

Verify that the correct port has been assigned to the channel.

Unable to set comm parameters on COMn

Error Type:

Fatal

Possible Cause:

The serial parameters for the specified COM port are not valid.

Solution:

Verify the serial parameters and make any necessary changes.

Communications error on COMn [<error mask>]

Error Type:

Serious

Error Mask Definitions:

B = Hardware break detected.

F = Framing error.

E = I/O error.

O = Character buffer overrun.

R = RX buffer overrun.

P = Received byte parity error.

T = TX buffer full.

Possible Cause:

1. The serial connection between the device and the host PC is bad.
2. The communications parameters for the serial connection are incorrect.

Solution:

1. Verify the cabling between the PC and the device.
2. Verify that the specified communications parameters match those of the device.

Device Status Messages

The following error/warning messages may be generated. Click on the link for a description of the message.

Device Status Messages

[Device '<device name>' is not responding](#)

[Unable to write to '<address>' on device '<device name>'](#)

Device '<device name>' is not responding

Error Type:

Serious

Possible Cause:

1. The serial connection between the device and the host PC is broken.
2. The communications parameters for the serial connection are incorrect.
3. The named device may have been assigned an incorrect Network ID.

Solution:

1. Verify the cabling between the PC and the device.
2. Verify the specified communications parameters match those of the device.
3. Verify the Network ID given to the named device matches that of the actual device.

Unable to write to '<address>' on device '<device name>'

Error Type:

Serious

Possible Cause:

1. The serial connection between the device and the host PC is broken.

2. The communications parameters for the serial connection are incorrect.
3. The named device may have been assigned an incorrect Network ID.

Solution:

1. Verify the cabling between the PC and the device.
2. Verify the specified communications parameters match those of the device.
3. Verify the Network ID given to the named device matches that of the actual device.

Device Specific Messages

The following error/warning messages may be generated. Click on the link for a description of the message.

Device Specific Messages

[Address size for device '<device name>' changed from '<old address size>' to '<new address size>'](#)

Address size for device '<device name>' changed from '<old address size>' to '<new address size>'

Error Type:

Information

Possible Cause:

This is not an error but a confirmation that the address size for the specified device has been changed.

Solution:

N/A

Index

- A -

Address '<address>' is out of range for the specified device or register 13
Address Descriptions 8
Address size changed 13
Address Validation 12
Allowed address range 4
Allowed addresses 4
Array size is out of range for address '<address>' 13
Array support is not available for the specified address: '<address>' 13

- B -

BCD 7
Boolean 7

- C -

Cable Diagram 3
Communications error on COMn [<error mask>] 15
Communications Timeout 7
COMn does not exist. 14
COMn is in use by another application 14

- D -

Daniels/Enron Addressing 9
Data Types Description 7
Device '<device name>' is not responding 15
Device address '<address>' contains a syntax error 12
Device address '<address>' is Read Only 13
Device ID 3
Device Specific Messages 16
Device Status Messages 15
DWord 7

- E -

Error Descriptions 11
Error opening COMn 14

- F -

Float 7
framing 15

- L -

LBCD 7
Long 7

- M -

mask 15
Memory 4
Memory size 4
Missing address 12
Modbus Addressing 8
Modbus Exception Codes 11
Modem Setup 4

- N -

Network 3

- O -

overrun 15
Overview 2

- P -

parity 15

- S -

Serial Communications 14
Short 7

- T -

Timeout 7

- U -

Unable to set comm parameters on COMn 14

Unable to write tag '<address>' on device '<device name>' 15

- W -

Word 7